

# BOLLY® 2 AP - HIGH PERFORMANCES

POLYWARM® COATED DOMESTIC HOT WATER CALORIFIER WITH 2 FIXED HEAT EXCHANGERS



## APPLICATION

Production and storage of domestic hot water.

## MATERIAL

Mild steel Polywarm® coated (Attestation ACS - SSICA - DVGW - W270 - UBA - WRAS)

## HEAT EXCHANGER

2 Polywarm® coated fixed heat exchangers

## INSULATION

High thermal insulation with ecological polyurethane hard foam.

Grey PVC external lining

## CATHODE PROTECTION

Magnesium anode.

## DRAIN

External confluence through drain connection.

## GASKET- FLANGE PLATE

Silicone gaskets suitable for alimentary use for max temperature up to 200°C. Mild steel inspection flange plate with Polywarm®

## WARRANTY

5 years - See general sales conditions and warranty

## ACCESSORIES AND SPARE PARTS

See Accessories section for the entire list.



HARD FOAM INSULATION

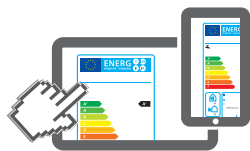

[www.cordivari.com/erp](http://www.cordivari.com/erp)

On line ErP label tool

## BOLLY® 2 AP WB

Model	HARD FOAM insulation Art. Nr.	HEAT EXCHANGER SURFACE		ENERGY EFFICIENCY CLASS 
		Upper	Lower	
		[m²]		
<b>200</b>	3135162325102	0,4	1,4	<b>B</b>
<b>300</b>	3135162320503	0,9	1,4	<b>C</b>
<b>500</b>	3135162320505	1,3	2	<b>C</b>

## ELECTRICAL IMMERSION HEATERS

Mod.	Volume of water heated by the electrical immersion [lt]	MONOPHASE		
		1,5 kW	2 kW	3 kW
		5240000000051	5240000000052	5240000000053
Ignition time from 10 °C to 45 °C with immersion heaters [min]				
<b>200</b>	54	88	60	44
<b>300</b>	105	188	141	94
<b>500</b>	172	307	230	154

## Accessories on request

### "Easy Control" Electronic Display

ART. NR.	FOR MODELS
5005000310003	WB



### Electrical immersion flange plate

See Accessories section



### Titanium electronic anode

Art. Nr.	Model
5200000000008	200, 300
5200000000009	500



# BOLLY® 2 AP- HIGH PERFORMANCES

POLYWARM® COATED DOMESTIC HOT WATER CALORIFIER WITH 2 FIXED HEAT EXCHANGERS

STORAGE		HEAT EXCHANGER	
Pmax	Tmax	Pmax	Tmax
10 bar	90 °C	12 bar	110 °C

**CORDIVARI Lab**  
TÜV Rheinland Energie und Umwelt GmbH states that test procedures and Cordivari LAB are certified conforming to European standard EN 15332, as indicated by Ecodesign ErP Directive.

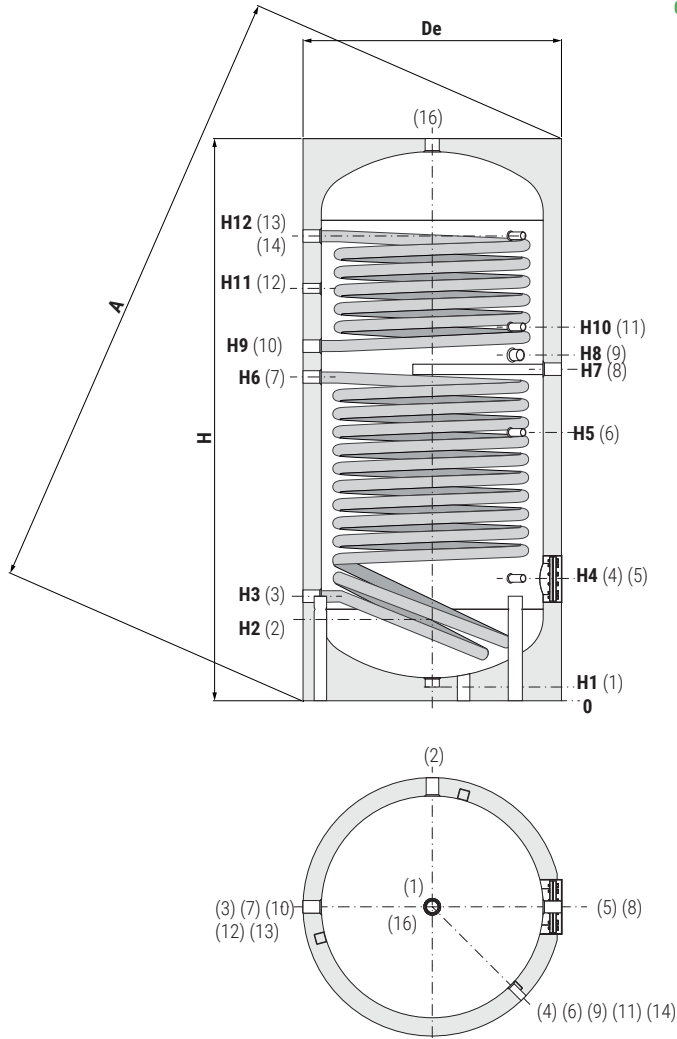
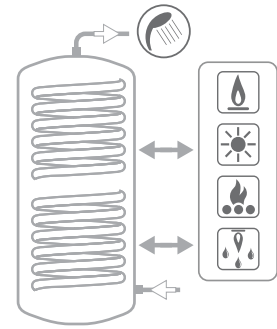

- |    |   |
|----|---|
| 1  | Drain 1"1/4 Gas F                               |
| 2  | Domestic cold water circuit inlet 1" Gas F      |
| 3  | Lower heat exchanger outlet 1"1/4 Gas F         |
| 4  | Connection for instrumentation 1/2" Gas F       |
| 5  | Blind flange for inspection Øi 120 mm           |
| 6  | Connection for instrumentation 1/2" Gas F       |
| 7  | Lower heat exchanger inlet 1"1/4 Gas F          |
| 8  | Connection for magnesium anode 1"1/4 Gas F      |
| 9  | Connection for electrical immersion 1"1/2 Gas F |
| 10 | Upper heat exchanger outlet 1"1/4 Gas F         |
| 11 | Connection for instrumentation 1/2" Gas F       |
| 12 | Recirculation 1" Gas F                          |
| 13 | Upper heat exchanger inlet 1"1/4 Gas F          |
| 14 | Connection for instrumentation 1/2" Gas F       |
| 16 | Domestic hot water outlet 1"1/4 Gas F           |

Model	Volume	Weight	De	H	A	H1	H2	H3
	[litres]	[Kg]						
<b>200</b>	189	67	550	1434	1535	71	220	285
<b>300</b>	291	82	650	1486	1622	71	246	311
<b>500</b>	498	131	750	1786	1937	71	271	346

Model	H4	H5	H6	H7	H8	H9	H10	H11	H12
	[mm]								
<b>200</b>	325	745	760	955	995	1015	1105	1115	1205
<b>300</b>	381	671	832	871	931	981	1076	1101	1221
<b>500</b>	411	896	1036	1076	1144	1186	1296	1331	1476

P.E.D. product designed and produced in conformity to the article 4.3 of directive 2014/68/UE - ErP Ecodesign directive 2009/125/CE

EXTRA-BOLLY® CALORIFIERS

BOLLYTERM® CALORIFIERS

STAINLESS STEEL CALORIFIERS

CALORIFIERS FOR HEAT PUMP

MULTIFUEL ENERGY CYLINDERS - PUFFER

HYDRONIC

INERTIAL TANKS

WATER PRESSURE TANKS

COMPRESSED AIR RECEIVERS

ACCESSORIES AND SPARE PARTS

TECHNICAL SUPPORT

# BOLLY® 2 AP- HEAT EXCHANGERS TECHNICAL DATA

Data have been calculated on following basis:

- 1) Primary circuit at T1 and proper energy source;
- 2) Production of DHW in continue way from 10 °C at t2;
- 3) DHW that can be taken in the first 10' and in the first hour from storage at 60°C, input 10°C and output 45°C;
- 4) Sanitary water according to UNI CTI 8065.

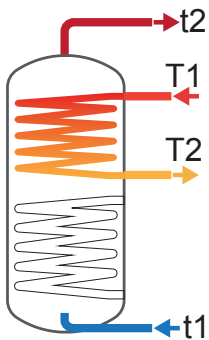

UPPER FIXED HEAT EXCHANGER

Model	Ignition time (minutes) from 10 °C to t2 and primary at T1				Maximum power exchange (kW) with primary at T1, secondary within 10-45 °C and constant use of DHW production				DHW continuous production lt/h within 10-45 °C and primary at T1			
	T1/t2				T1				T1			
	55/50	65/60	70/60	80/60	55	65	70	80	55	65	70	80
300	41	43	30	20	9,9	15	17,5	22,8	243	368	432	562
	47	48	34	22	9,1	13,6	15,8	20,4	223	333	389	503
500	49	51	35	23	14,4	22,5	25,9	32,8	353	532	623	809
	55	57	40	26	13,3	19,6	22,8	29,3	326	482	562	724

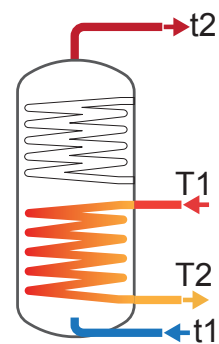

LOWER FIXED HEAT EXCHANGER

Model	Ignition time (minutes) from 10 °C to t2 and primary at T1				Maximum power exchange (kW) with primary at T1, secondary within 10-45 °C and constant use of DHW production				DHW continuous production lt/h within 10-45 °C and primary at T1			
	T1/t2				T1				T1			
	55/50	65/60	70/60	80/60	55	65	70	80	55	65	70	80
300	82	85	60	39	15,6	23,4	27,3	36,3	384	576	673	871
	94	98	69	45	14,6	21,2	24,6	31,6	354	522	607	778
500	100	104	73	48	22,3	33,2	38,7	49,9	549	820	956	1234
	115	120	85	56	20,6	30	34,7	44,3	506	741	858	1095

## PRESSURE LOSS - FIXED HEAT EXCHANGERS BOLLY® 2 AP



### UPPER

Heat exchanger surface [m <sup>2</sup> ]	
200	0,4
300	0,9
500	1,3

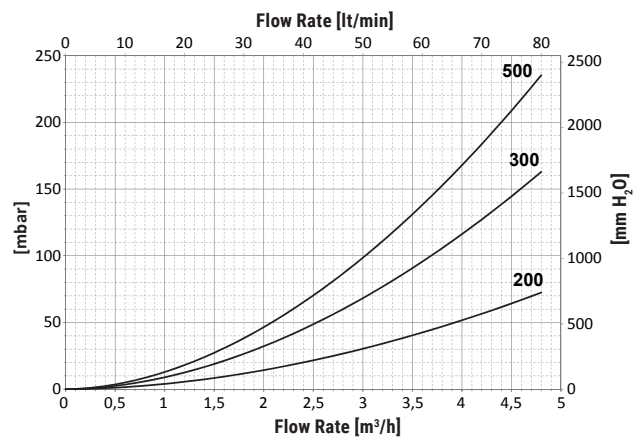

### LOWER

Heat exchanger surface [m <sup>2</sup> ]	
200	1,4
300	1,4
500	2

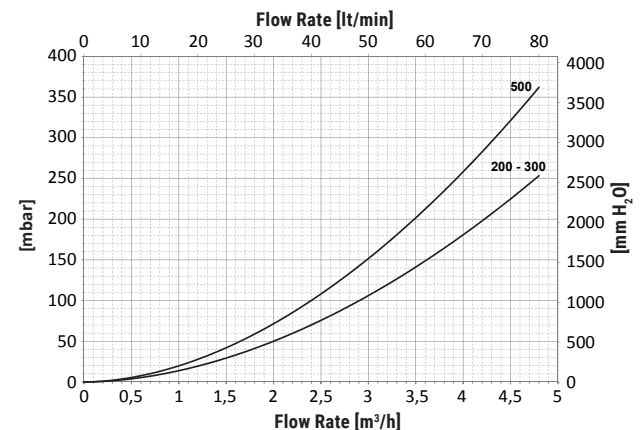

DHW produced in the first 10 minutes in lt/10' input 10 °C output 45 °C, storage at t2 and primary at T1				DHW produced in the first hour in lt/60' input 10 °C output 45 °C, storage at t2 and primary at T1				Flow rate [m³/h]	Exchanger pressure loss	
T1/t2				T1/t2					[mm.H <sub>2</sub> O]	[mbar]
55/50	65/60	70/60	80/60	55/50	65/60	70/60	80/60			
149	197	208	229	303	430	481	585	3	194,65	19,09
146	191	201	220	287	402	447	538	1,5	53,92	5,29
242	317	332	363	465	654	727	876	3,5	316,51	31,04
237	309	322	349	444	614	678	808	1,75	87,68	8,60

DHW produced in the first 10 minutes in lt/10' input 10 °C output 45 °C, storage at t2 and primary at T1				DHW produced in the first hour in lt/60' input 10 °C output 45 °C, storage at t2 and primary at T1				Flow rate [m³/h]	Exchanger pressure loss	
T1/t2				T1/t2					[mm.H <sub>2</sub> O]	[mbar]
55/50	65/60	70/60	80/60	55/50	65/60	70/60	80/60			
397	512	528	561	640	877	954	1113	3	1082,03	106,11
392	503	517	545	616	833	901	1038	1,5	299,73	29,39
660	847	869	916	1007	1366	1475	1697	3,5	2056,48	201,67
652	834	853	893	973	1303	1396	1586	1,75	569,66	55,86

## HEAT EXCHANGERS OUTPUT CHART BOLLY® 2 AP

HEAT EXCHANGER OUTPUT REFERRED TO TEMPERATURE AND FLOW RATE OF PRIMARY CIRCUIT AND WITH SECONDARY AT 10/45°C AT MAXIMUM WITHDRAWAL OF PRODUCIBLE DHW (UPPER LIMIT OF THE CURVES REFERRED TO MAXIMUM PRIMARY FLOW RATE IN THE HEAT EXCHANGER, WHILE THE LOWER LIMIT IN THE CURVE REFERS TO THE MINIMUM PRIMARY FLOW RATE)

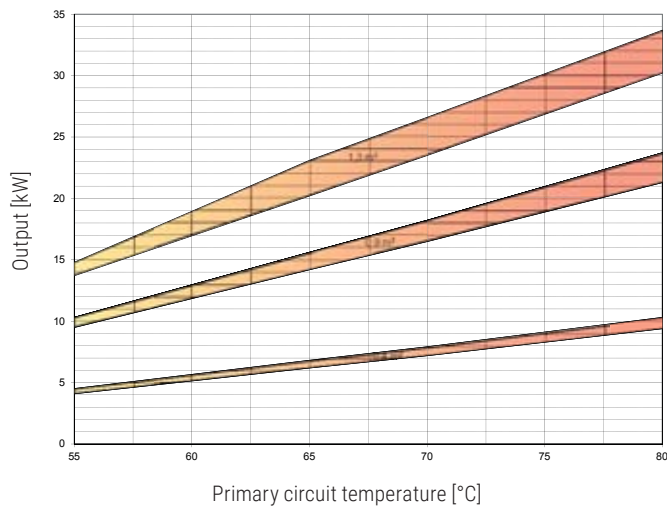

Heat exchanger surface	0,4 m <sup>2</sup>		0,9 m <sup>2</sup>		1,3 m <sup>2</sup>	
	MAX	MIN	MAX	MIN	MAX	MIN
Flow rate [m³/h]	2	1	3	1,5	3,5	1,75

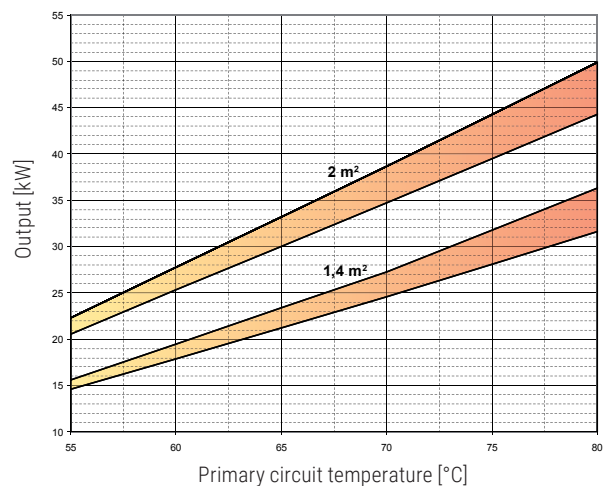

Heat exchanger surface	1,4 m <sup>2</sup>		2 m <sup>2</sup>	
	MAX	MIN	MAX	MIN
Flow rate [m³/h]	3	1,5	3,5	1,75